

Intro to Process Technology

During the first week of a 12 week course, students will be given a pre-test for evaluation and then taught basic math skills related to Process technology. Conversion tables utilized are from Davis, D.D.(1995) . *Practical Problems in Mathematics for Manufacturing*. Albany, NY: Delmar. ISBN:0-8273-6710-4

First Class Day (after pre-test)

Students will be introduced to the different units of measure for length, area and volume. The following handout entitled units of measure will be given to the students for reference of common equivalencies and to make notes of sample conversion problems.

Sample Exercises

72 inches is how many feet?

We know that 12inches equals one foot so you divide 72 by 12 to get 6 (the amount of feet in 72 inches.)

How many inches are in 8 feet?

Do the reverse of the previous example. Multiply 8 by 12 to get the number of inches which is 96.

Take a square whose side is a length of 6. If you wanted to calculate the perimeter (length around the sides of the square) and area of the square how would you do this?

First, you would have to know that units of length are in feet and inches and that the area will have units of square feet and square inches.

To calculate the perimeter of the square you take the length of a side and multiply it by 4. Why 4? Because a square has 4 sides. In this example you would have: $6 \times 4 = 24$ inches or 2 feet. Remember that 12 inches equals one foot.

To calculate the area follow this formula: length of a side x length of a side, therefore, $6 \text{ inches} \times 6 \text{ inches} = 36$ square inches or 3 square feet.

Your final answer will be square feet or inches because you multiplied two like units of measure. Remember that you can only multiply units of like measure.

Instructor can then substitute different numbers for the length of measure and different units of measure (metric) for the students to try on their own. Use real life applications of this math while showing the above samples such as how much tile flooring you will need to cover the floor of a room that is 10 feet x 13 feet? This will allow the student to identify these skills in real life and will better understand.

Second Class Day

Circles

Many pipelines and storage tanks are cylindrical in shape, meaning that they are in the shape of a circle all around. Below are definitions that are mandatory to know.

Circumference: the length around the outer edge of a circle.

Diameter: the width of a circle or cylindrical feature.

Radius: half of the diameter measure

Pi (pronounced "pie"): constant which stands for the value of 3.14

To calculate the circumference of a circle, you must first realize that it's a length and should be expressed in inches, feet, or yards. The formula is as follows:

circumference = $\pi \times \text{diameter}$

To calculate the area: $\pi \times \text{radius squared}$. This means you multiply the radius given by itself to get an answer. For example, if the radius is 4 then you would multiply 4×4 to get 16.

Sample Exercises

What is the circumference of a circle with a diameter of 10 inches?

What is the circumference of a circle with a radius of 4 inches?

What is the area of a circle with a radius of 5 inches? Remember to express your answer in square inches.

What is the area of a circle with a diameter of 2 inches? Remember to express your answer in square inches.

What is the area and circumference of a circle with a diameter of 8 inches? Give your answers in feet and inches AND square feet and inches.

On their own, students will complete the last page of the hand-out titled Units of Measure. Try to have objects of cylindrical shape to use in the lecture for the students to grasp the mathematical formulas.

Third Class Day

Volume

On the handout entitled Units of Measure, the first page on the bottom has the definition for volume and important conversion factors. Volume is measured in gallons, cubic feet, quarts, fluid ounces and cubic inches.

Remember that in circumference and area our answers were expressed in square inches or feet, with volume our answers will be expressed in cubic feet, inches or yards. Cubic comes from the word cube. When answers are cubed, that means that three units of like measure were involved in the formula.

Below are the two formulas we will use to solve for volume.

Volume of a square: area of the square x height

Volume of a cylinder: area of the circle x height.

Sample Problems

What is the volume in cubic inches, of a rectangular solid that has the following dimensions?

Length=0.8

Width= 0.3

Height= 0.2

First find the area using the formula for area and then multiply it by the height to get the answer.

What is the volume in cubic inches, of a tube that has the following dimensions?

Diameter= 1

Height= 3

First find the area of a circle using the formula for area and then multiply by the height given in the problem.

What is the volume in cubic feet and gallons of a cylindrical tank that is 5 feet in diameter and 10 feet in height?

The area of the circle is $3.14 \times 2.5\text{feet} \times 2.5\text{ feet}=19.625$ square feet.

The volume of the cylinder is $19.625\text{feet} \times 10\text{feet}=\mathbf{196.25}$ cubic feet.

196.25 cubic feet $\times 7.48$ gallons/1 cubic foot= **1467.95 gallons.**

First find the area and then the volume and then convert to gallons using the conversion table from the referenced text.

Students will measure different size objects like soda cups or cans and have them find the volume in the different units of measure for volume. Students will record their findings in a table. Practice on how to convert from the imperial system (feet and inches) to metric.

Units of Measure

Length : The length of something is the amount that it measures from one end to the other along the longest side. It is measured in feet, inches and yards.

$12''=1'$ (12 inches equals one foot)

$3'=1\text{yd}$ (3feet equals 1 yard)

Area: The amount of flat space. Measured in cubic inches, cubic feet, cubic yards

Volume: The amount of space that something contains or occupies. It is typically measured in gallons, pint, quart, fluid ounces.

1 cubic foot= 7.48 gallons

1 quart= 2 pints= 32 fluid ounces

1 gallon= 4 quarts= 128 fluid ounces

1 cubic foot= 1728 cubic inches

1 fluid ounce= 1.80 cubic inches

Lengths of sides

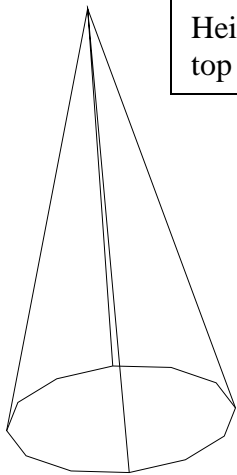
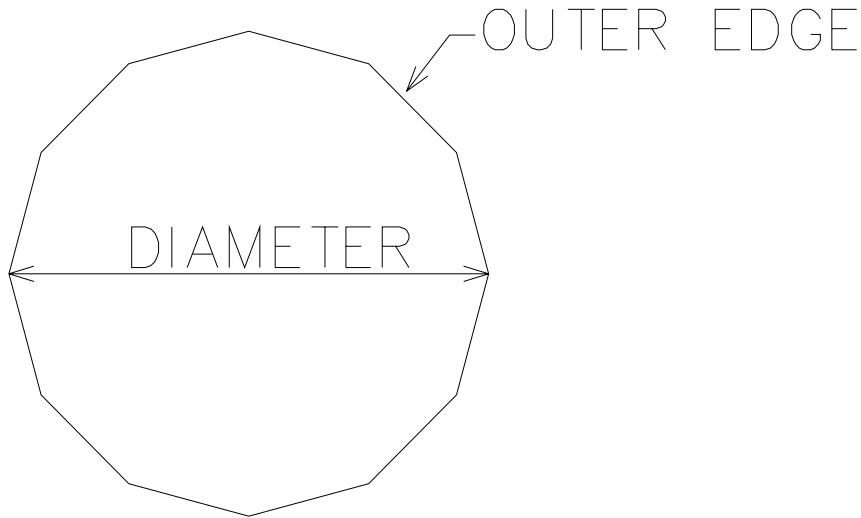
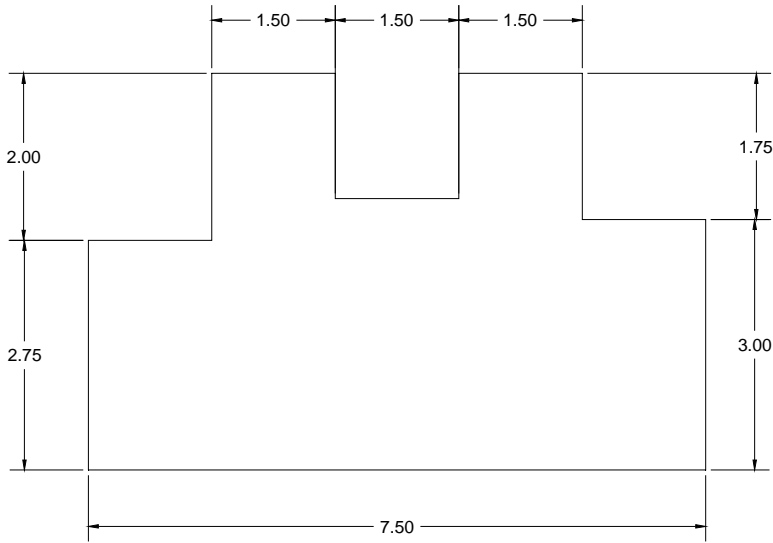

Height of a cylinder is from the top tip to the center of the base.

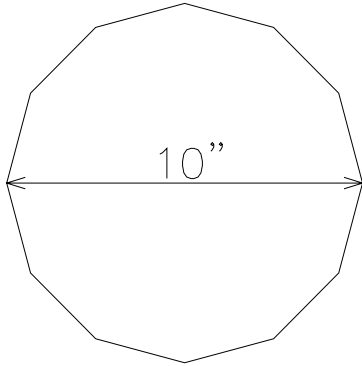

Calculate the circumference and area of the circle above. Give your answer in feet and inches AND square inches and feet.

Feet	Inches	SQ. Inches	SQ. Feet
------	--------	------------	----------

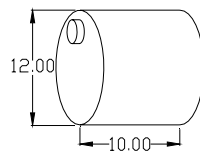

Given the above object, calculate how many gallons and milliliters of water the tank will hold?